

TLD93
off-road dump truck



Add : NO.2339, Fengchan Road, Fengdong New District, Xi'an City, Shaanxi Prov, China
Sales Tel : +86-29-38001214 Service Tel : +86-29-33687710, 4006-863-853
Website : <https://www.tonlyoverseas.com>

Local contact

Components Introduction

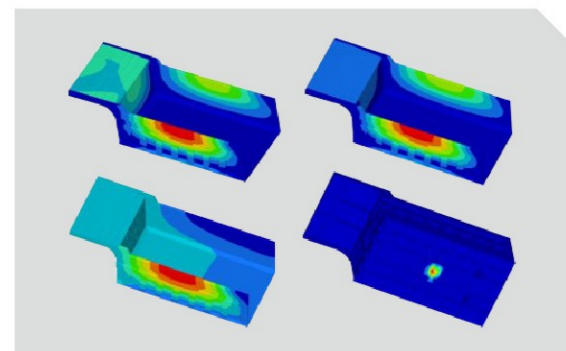

1 Cargo body

Reinforced structure with strong impact resistance.



2 Tire

Special mining tire for mine only with longitudinal and transverse groove design, which provide excellent grip performance and comfort of operation strong carrying capacity and long service life.

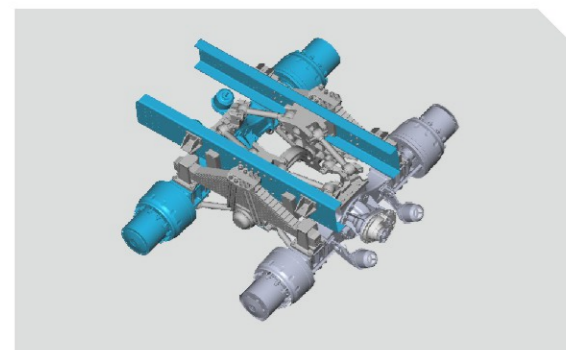

3 Suspension

The front suspension multi-level shock absorption element to improve driving comfort. The rear leaf spring clamping mechanism with TONLY patent is reliable and practical.



4 Intake system

Three stage combined air filter can improve the efficiency of air filtering, and improve the air clearness.



5 Hydraulic retarder

Transmission combined with hydraulic retarder can reduce the speed of the truck when going down a long slope, works long time and high power, reduce the wear out of braking components and extend the tire life time, ensure the operation safety.



6 FOPS/ROPS certificate

Tonly product is the only one obtained the certificate for big payload through severe test.



7 Steering system

Tonly developed full hydraulic steering system (TONLY owns all patent of this technology), reduce the steering oil temperature, steering operation is lighter, greatly improve the life cycle of the system components, and ensure the truck safety.



8 Anti-collision structure

Anti-collision beam + bumper + through beam structure, effectively protects the driver and the truck.



TLD93 off-road dump truck

This dump truck is equipped with electronically controlled engine and automatic gearbox, with easy operation and high efficiency. The application of information and automation technology makes the management of mining equipment more efficient. Longer service life, lower transportation costs and more economical use due to the perfect combination of lightweight technology and reliability.

Main system characteristics

➤ Engine

- New performance-optimized engine, high efficient and fuel-saving.
- 15L/16L large displacement, strong power and wide power range.



➤ Automatic transmission

- High reliability and torque transmission capability.
- The integrated hydraulic retarder provides excellent auxiliary braking capability for heavy-duty trucks and improves operation safety.



➤ Lifting device

- Selected mining special oil cylinder system, which has better stability and greater thrust.
- Optimized design of connecting support, strengthened support and improved lifting safety.



➤ Axle Assembly

- TONLY and HANDE jointly design the special axle for mine transportation. Strengthened single casting axle housing, double reduction.
- Big torque, high transmission efficiency and high reliability.



➤ Main frame

- Flexible bolt and rivet connection frame type with high torsional bearing efficiency and long service life.

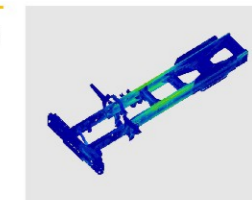

➤ The fourth generation cab

- Special cab for mining truck with large space, wide visible range and comfortable manipulation.
- Compression molding Interior with lower noise and good quality.



Overall parameters	Model	TLD93
	Brand	Tonly
	Drive mode (t)	6×4
	GVW (t)	107
	Rated payload (t)	72
	Kerb weight (t)	35
	Dimensions (mm)	10044X3740X4242
	Wheelbase (mm)	4075+1750
	Wheel track (mm)	2750/2594
	Minimum ground clearance (mm)	400
	Minimum turning radius (m)	11
	Maximum height of bucket lift (mm)	8796
	Maximum angle of bucket lift (°)	48
	Loading height (mm)	4032
	Braking distance (m)	17
Maximum climbing degree (%)	≥30	
Maximum speed (km/h)	40	
Engine	Model	QSZ14
	Manufacturer / Country	DCEC/China
	Power (hp/kw)	560/418
Transmission	Model	FC6A250DPRT
	Manufacturer / Country	Fast/China
Axle	Manufacturer / Country	Hande/China
Tire / Rim	Load/T	25+40+40
	Tire model	16.00-25
	Rim size	11.25/2.0-25

Container	Base plate material/thickness (mm)	NM400/16
	Rear plate material/thickness (mm)	NM400/12
	Front plate material/thickness (mm)	T700/10
	Side plate material/thickness (mm)	T700/10
	Container volume (m ³)	36
Hydraulic system	Model	FC191
	Manufacturer / Country	HYVA/China
	Steering device	Fully hydraulic steering
	Lifting time (s)	27
	Discharge time (s)	27
Weight distribution	Empty load	
	Front axle (kg)	15000
	Rear axle (kg)	20000
	Total weight (50% fuel) (kg)	35000
	Loaded	
	Front axle (kg)	25000
Rear axle (kg)	80000	
	Total weight (kg)	105000

