

Add : NO.2339, Fengchan Road, Fengdong New District, Xi'an City, Shaanxi Prov, China
Sales Tel : +86-29-38001214 Service Tel : +86-29-33687710, 4006-863-853
Website : <https://www.tonlyoverseas.com>

Local contact

TLS753

off-road mining sprinkler truck



Components Introduction



1 Water tank

The oversized tank body designed with the chassis of off-road dump truck meets the watering requirements under various working conditions. There are wave baffles inside the tank, which can effectively relieve the impact of water inside the tank and improve reliability.



3 Tire

Special mining tire for mine only with longitudinal and transverse groove design, which provide excellent grip performance and comfort of operation strong carrying capacity and long service life.

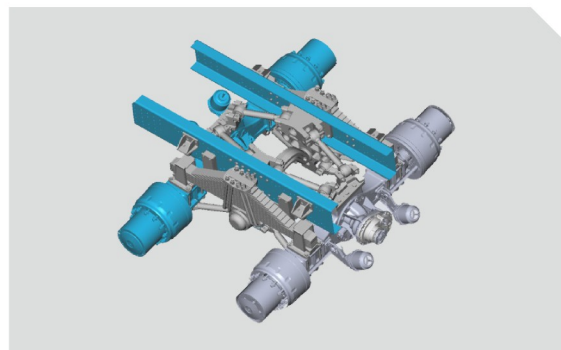

2 Suspension system

The front suspension multi-level shock absorption element to improve driving comfort. The rear leaf spring clamping mechanism with TONLY patent is reliable and practical.



4 Intake system

Three stage combined air filter can improve the efficiency of air filtering, and improve the air clearness.

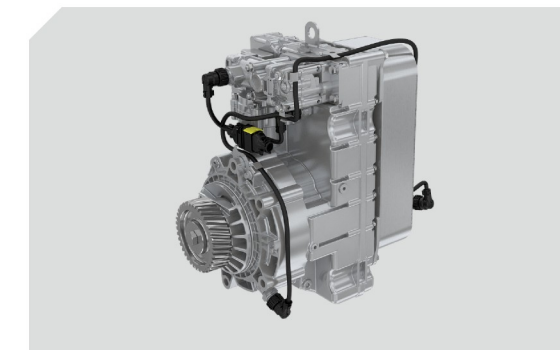
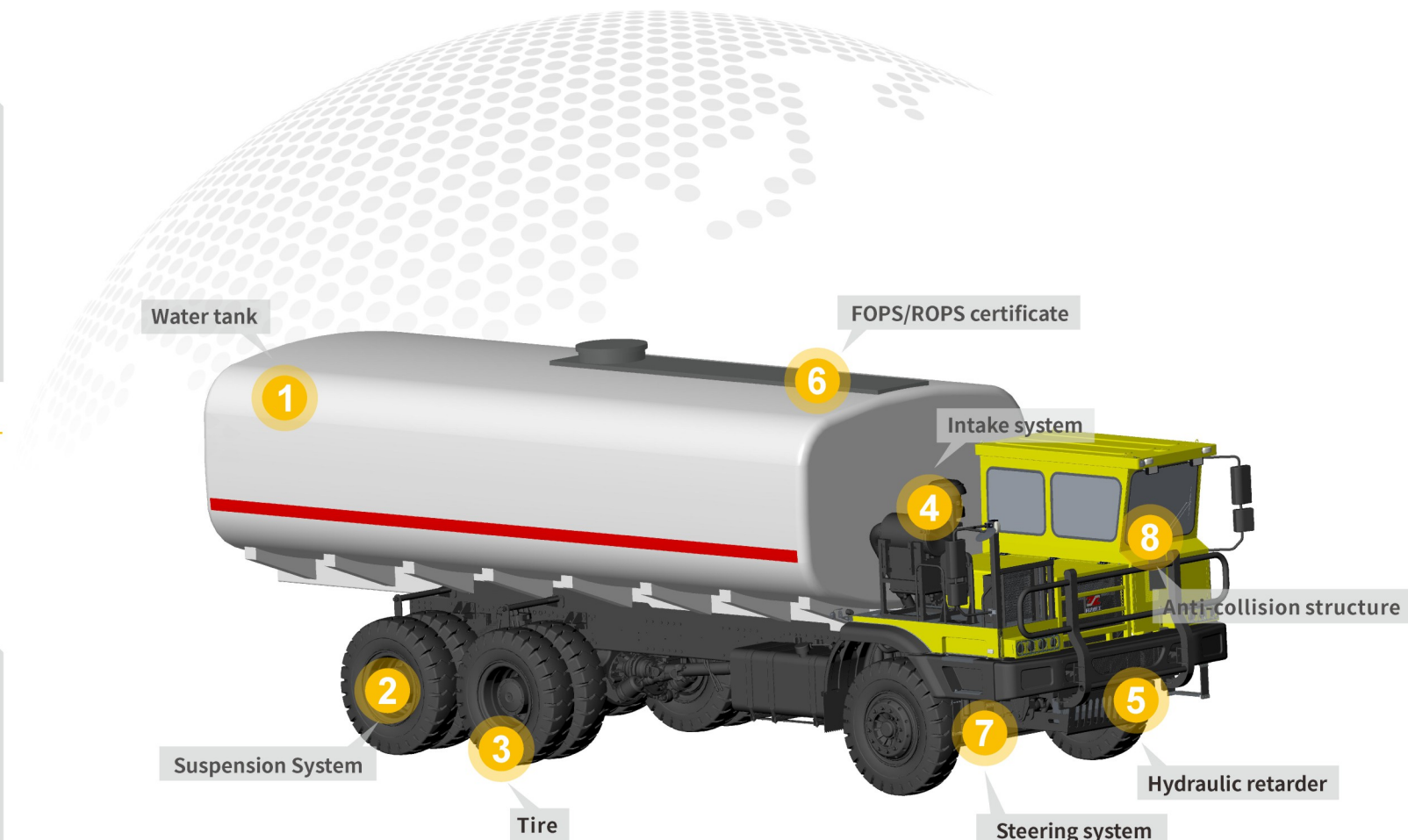

5 Hydraulic retarder

Transmission combined with hydraulic retarder can reduce the speed of the truck when going down a long slope, works long time and high power, reduce the wear out of braking components and extend the tire life time, ensure the operation safety.



7 Steering system

Tonly developed full hydraulic steering system (TONLY owns all patent of this technology), reduce the steering oil temperature, steering operation is lighter, greatly improve the life cycle of the system components, and ensure the truck safety.



6 FOPS/ROPS certificate

Tonly product is the only one obtained the certificate for big payload through severe test.

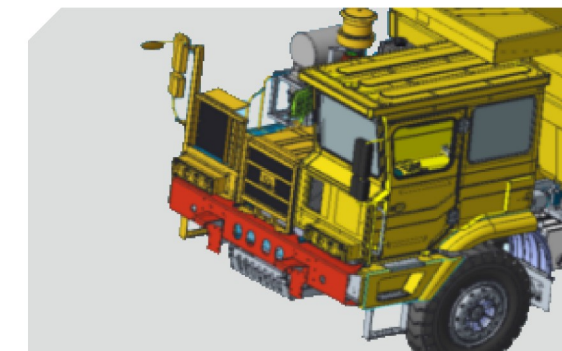

8 Anti-collision structure

Anti-collision beam + bumper + through beam structure, effectively protects the driver and the truck.



TLS753 off-road mining sprinkler truck

Fire-fighting function: Equipped with 25m range water gun, it can be used as a temporary fire truck.

Greening function: The sprinkler system has a mixing function, which can mix pesticides and spray trees & green belts.

Water suction and pumping function: It can suck water and store it in the water tank, and transport water for production & operation.

Main system characteristics

➤ Engine

- New version with performance optimization, high efficiency and fuel saving.
- 12L large displacement, strong power & wide power range.

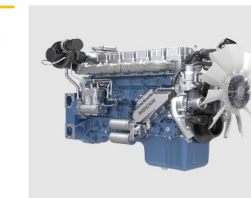

➤ Transmission

- Single box and double intermediate shaft with simple structure, reasonable speed ratio, which is economical and practical.
- The optimized shaft and gear improve the service life.

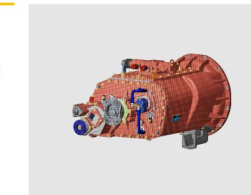

➤ Main chassis frame

- Flexible bolt and rivet connection frame type with high torsional bearing efficiency and long service life.

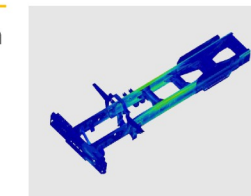

➤ Axle

- TONLY and HANDE jointly design the special axle for mine transportation. Strengthened single casting axle housing, double reduction.
- Big torque, high transmission efficiency and high reliability.



➤ Mining special cab

- Special cab for mining truck with large space, wide visible range and comfortable manipulation.
- Compression molding Interior with lower noise and good quality.



➤ Lifting system

- Selected mining special oil cylinder system, which has better stability and greater thrust.
- Optimized design of connecting support, strengthened support and improved lifting safety.



➤ Water cannon

- Large flow, long range and wide coverage.
- Cab remote control, easy to operate.



Overall parameters	Model	TLS753
	Brand	Tonly
	Drive mode	6×4
	GVW (t)	72
	Rated payload (t)	50
	Kerb weight (t)	22
	Dimensions (mm)	11295×3340×3965
	Wheelbase (mm)	5075+1550
	Wheel track (mm)	2661/2468
	Minimum ground clearance (mm)	305
	Minimum turning radius (m)	12.6
	Braking distance (m)	12
	Maximum climbing degree (%)	≥32
Maximum speed (km/h)	40	
Engine	Model	WP12G430E310
	Manufacturer / Country	Weichai/China
	Power (hp/kw)	430/316
Transmission	Model	7DS180
	Manufacturer / Country	Fast/China
	Input torque (N·m)	1800

Axle	Manufacturer / Country	Hande/China
	Load/T	20+35+35
Tire / Rim	Tire model	14.00-25
	Rim size	10.0/2.0-25
Water Pump	Model	80QZB60/90S
	Manufacturer / Country	Hangzhou Weilong/China
Tank	Inner cavity size (mm)	8100×3250×2200
	Plate thickness	Tank body 6mm; wave stopper 6mm (6 pieces)
	Material	Q355B (optional stainless steel material)

